

CLASS 10000 MAG SERIES 12

RH ROTATION

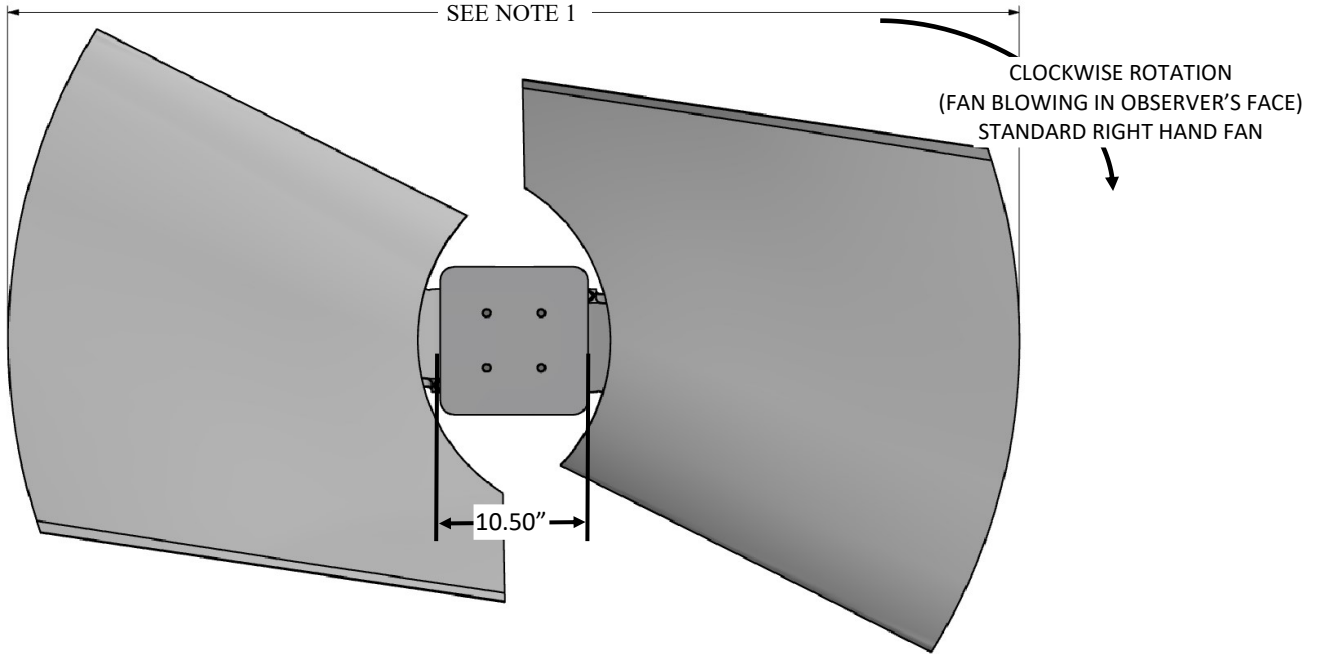

NOTE 1:
 MAXIMUM FAN DIAMETER EQUALS NOMINAL FAN DIAMETER.
 INWARD ADJUSTMENT OF 0.25" IF NEEDED.

- A = BLADE TIP PROFILE HEIGHT (PATH WIDTH)
- B = BLADE RUNNING DROOP (C/L TO BOTTOM OF BLADE)
- C = MAXIMUM DROOP POSITION OF BLADES AT 30° (C/L TO BOTTOM OF BLADE)
- D = MINIMUM OBSTACLE CLEARANCE AT INLET
- F = CENTERLINE OF FAN TO BASE OF BUSHING (STANDARD HUB WITHOUT EXTENSION)
- G = BUSHING OVERALL HEIGHT
- H = MAXIMUM HEIGHT OF BLADE AT 30° (C/L TO AIR OUTLET SIDE)
- L = MAX . BUSHING TORQUE FT. LBS.
- # = WITH S.A.E. STANDARD SQUARE KEYWAY
- * = WITH SHALLOW KEYWAY IN BUSHING
- o = MAX METRIC BORE WITH STANDARD KEYWAY

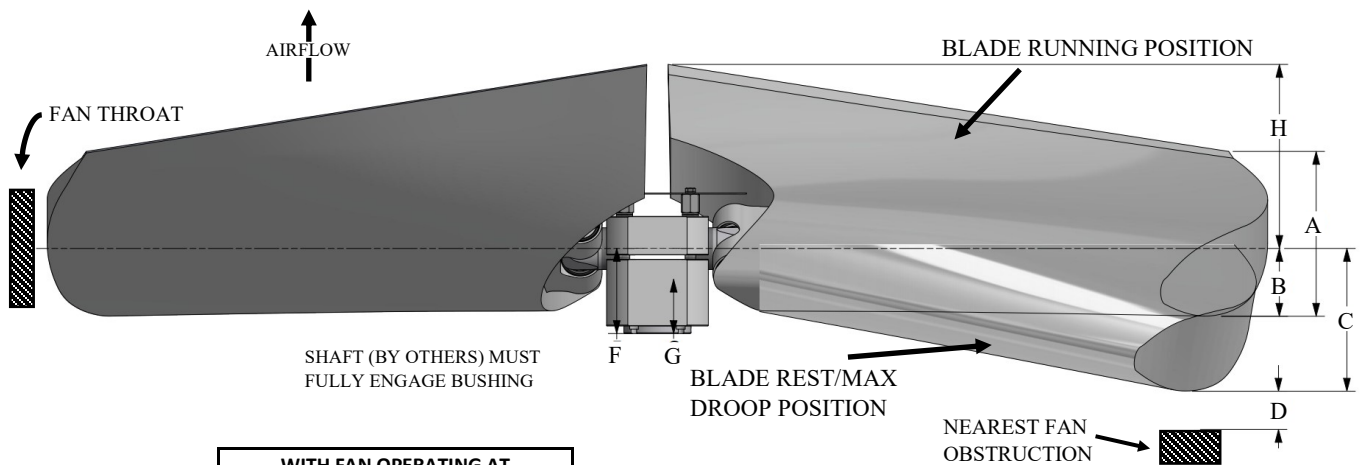

SHAFT (BY OTHERS) MUST FULLY ENGAGE BUSHING

WITH FAN OPERATING AT 12000 FT/MINUTE BLADE TIP SPEED

DIA	BLADE ANGLE			PERCENT BLADE		C	D	H
	10°	20°	30°	100%	75%			
	A	B	C	D	H			
5'	9.0"	14.0"	19.3"	13.4"	13.2"	14"	6"	16.5"
5.5'	9.0"	14.0"	19.3"	13.7"	13.4"	14.4"	6"	16.5"
6'	9.0"	14.0"	19.3"	14"	13.6"	14.9"	6"	16.5"

MAX BLADES	BUSHING TYPE	MAX # BORE	MAX * BORE	MAX o BORE	F	G	L
3	U	2.750"	2.938"	75	2.525"	2.7"	4000