

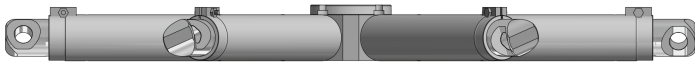

CLASS 10000 SC & EC

Installation Instructions

INSTALL MANUAL HUB AND AIR SEAL



Hub Only Without Air Seal



Air Seal Installed on Hub

Hub Installation Instructions:

Lubrication:

The aluminum bushing is lubricated and pre-installed in the hub at the factory, no further lubrication is required prior to installation. **DO NOT** apply lubricant between the bushing bore and the shaft.

If bushing not pre-installed:

Install the bushing in the hub by aligning the threaded holes on the ID of the hub with the slots on the OD of the bushing with the cap screws captured between the bushing and the hub. Ensure that the shaft set screw in the bushing is on the same side as the access hole in the hub. Apply high quality grease to the tapered face then insert the bushing in the hub. Using a hex key wrench, sequentially tighten the socket head cap screws until the bushing is almost fully engaged in the hub.

Installation:

Install the bushing in the hub by aligning the threaded holes on the I.D. of the hub with the slots on the OD of the bushing with the cap screws

captured between the bushing and the hub. Insert the bushing in the hub. Using a hex key wrench, sequentially tighten the socket head cap screws until the bushing is almost fully engaged in the hub. Leave slight play between the bushing and hub to facilitate installation on the shaft. Place the hub/bushing on the shaft. (Preferably cap screw heads will be towards free end of shaft.) Insert the key, and tighten the setscrew to secure the hub and key to the shaft. Now begin sequentially tightening the socket head cap screws (approximately 2-3 turns per cap screw initially) to firmly engage the bushing in the hub and seat the bushing on the shaft. Once the bushing/hub is firmly seated on the shaft, continue tightening the cap screws sequentially until the specified torque, shown in the table, is reached. **DO NOT** over-tighten cap screws as this could cause damage to the hub.

Caution:

If bushing is expected to see frequent oscillating loads (greater than 50% of nominal expected static torque), fan should be operated for approximately 15 minutes and then re-torque bushing cap screws.

Bushing Type	Bushing OD	Allen Head Bolt	Hex Key Size	Required Torque
U	4"	12mm	10mm	50 ft-lb(6.9 m-kg)
W	5.5"	16mm	14mm	90ft-lb(12.5 m-kg)
Z	7"	16mm	14mm	135 ft-lb(18.7 m-kg)

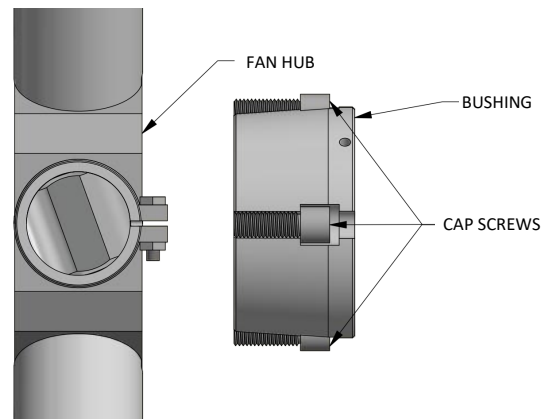

To Install the Air Seal:

Locate the air seal installation hardware in the plastic bag taped to one of the hub tubes. Install the air seal studs on the appropriate side of the hub tube and finger tighten. Place one resilient washer on each stud as shown in the drawings. Place the air seal onto the studs and install the remaining hardware, following the sequence shown in the drawings. Do not lubricate this end of the studs. Note that the diameter of the resilient washers, before they are compressed, is slightly less than the diameter of the aluminum washer. Tighten each nut until the resilient washer's di-

ameter is the same as the aluminum washer. Do not overtighten. Overtightness exists when the resilient washer has expanded in diameter larger than the diameter of the aluminum washer. Note: Some air seals are provided with more mounting holes than may be required. This is done intentionally to make the air seals more interchangeable between units. For example, an air seal with 8 mounting holes can be used with either a 4-blade or an 8-blade unit.

INSTALL AND ADJUST BLADES

Before installing blades check to see that the hub is level. If the drive shaft is not truly horizontal (or vertical), causing the hub to be cocked, it will be difficult to adjust blade angles accurately. Eccentric rotation of the fan can also cause serious vibration problems. If misalignment, vibration or unbalance in the system is present, it will be more easily identified and corrected at this time. Moore fan blades are carefully balanced to the same moment at the factory. Any Class 10000 blade of the same series and diameter may be installed on any hub furnished on the job. They are completely interchangeable. **Proper installation, with particular attention to tightening nuts to the specified torque, is essential to maintain the design integrity of these units.** Install one blade: Clean any dirt or grease from the rod end and the surfaces of the resilient mounts. Align the rod end hole with the holes in the resilient mounts and insert the blade mounting bolt first through the resilient mount with the recess to accept the bolt head, then through the rod end hole and screw the bolt into the second resilient mount lightly. A 3/4" drive torque wrench with a short extension may be used. The blade mounting bolt is supplied from the factory with grease on the threads and conical face.

Do NOT clean the grease from the bolt. Complete the installation of one blade by holding the blade so that the blade extends straight out from the hub tube. Holding the blade in this position, **tighten the bolt using a torque wrench set to 200 ft-lb (28 m-kg) making sure the rod end and the resilient mounts seat.** After installing the first blade, manually rotate the fan while moving the blade tip in and out to be sure the blade clears the ring or throat at all points. When the blade is held in alignment with the blade tube (that is, straight outward from the hub), it should clear the fan ring by a distance adequate to provide for any relative motion between the fan wheel and the ring. Excess clearance between the blade tips and the ring, however, should be avoided to prevent backflow which seriously reduces fan efficiency. If clearance is excessive, the diameter may be adjusted at this time. Install the rest of the blades so that they are identical with the first blade. A variation in the blade tip elevation is normal in the stop position. **Torque all bolts to 200 ft-lbs. (28 m-kg).** If blades are installed properly, they will return to their undisturbed position if the tips are pressed in the axial direction with moderate force (10 to 20 lb).

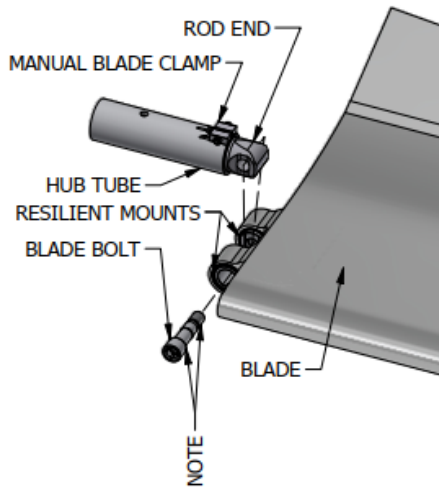

WARNING!
CUIDADO!
ATTENTION!
Blade bolt and clamp bolt **MUST** be tightened to torque values shown here for proper fan operation. It is also essential that the indicated surfaces are properly lubricated. For further information, see the owner's manual, or call USA (660)376-3575 FAX(660)376-2909

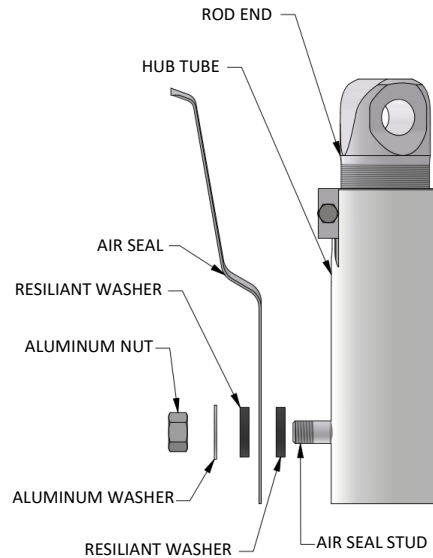

ADJUST BLADE ANGLE

Hubs are shipped from the factory with the rod end set for the blade angle indicated by the design performance. A change in blade angle is sometimes necessary to adjust to actual site conditions. Failure to adjust the blade angle when required may result in blade or motor overload. To adjust, loosen the Clamp Nut just enough to allow the blade to be turned. Place an inclinometer on the flat surface of the mounts end. Turn the blade until the desired angle is achieved. Make a permanent record of

the final angle selected and take care that all blades on the fan are set at the same angle. A typical adjustment may be +/- 3°. **The maximum recommended blade angle is 30°.** Please consult the factory if it is desired to go above this. **Retighten the Clamp Nut to 18 ft-lbs. (2.5 m-kg)** while holding the blade in this position. **Recheck each blade angle after tightening.**

ADJUST DIAMETER IF REQUIRED

At times it may be necessary to adjust the fan diameter to suit a particular ring. To do so, loosen the clamp nut so that the rod end can be rotated in the hub tube. One complete revolution will increase or decrease the radius of the fan by .059" (1.5 mm). Take care that the rod end is returned to exactly the factory-set angle unless it is intended that the blade loading be changed as discussed in the previous section. A match mark

may be made at a point on the threads and the tube before turning to assure that exactly one revolution is made. **Tighten the clamp nut to 18 ft-lbs. (2.5m-kg).** *Maximum adjustment possible is about +/- 0.75" (19 mm). At least 1.0" (25 mm) of rod end threads must remain in the tube. *Maximum adjustment possible on blades with ATEX tips is +1.0" & - .5".