

# CLASS 10000 HD SERIES 24 SC

## STANDARD HUB, RH ROTATION

**Moore**  
FANS

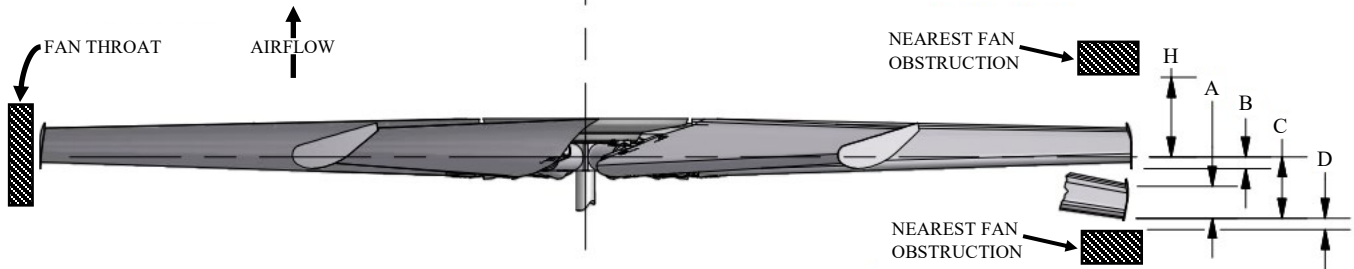
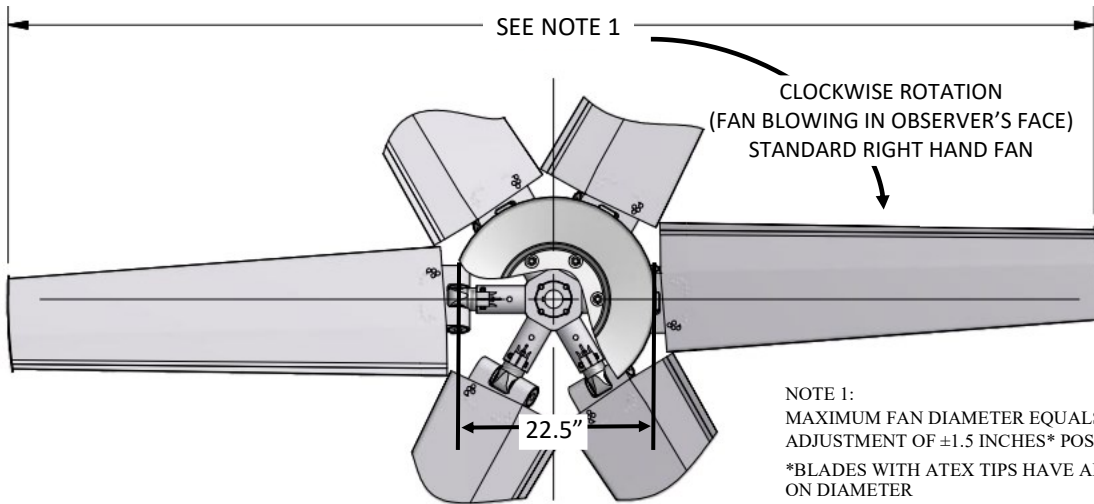
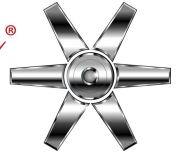

- A = BLADE TIP THICKNESS @ 19° BLADE ANGLE
- B = RUNNING POSITION OF BLADES
- C = MAXIMUM DROOP POSITION OF BLADES
- D = MINIMUM OBSTACLE CLEARANCE AT INLET
- F = CENTERLINE OF FAN TO BASE OF BUSHING
- G = BUSHING OVERALL HEIGHT
- H = MINIMUM OBSTACLE CLEARANCE AT OUTLET
- I = NOMINAL MECHANICAL HUB DIAMETER
- L = MAXIMUM BUSHING TORQUE FT. LBS.
- # = WITH S.A.E. STANDARD SQUARE KEYWAY
- \* = WITH SHALLOW KEYWAY IN BUSHING
- o = MAX METRIC BORE WITH STANDARD KEYWAY

BUSHING AND/OR AIR SEAL  
CAN BE INSTALLED ON INLET  
OR OUTLET SIDE OF FAN

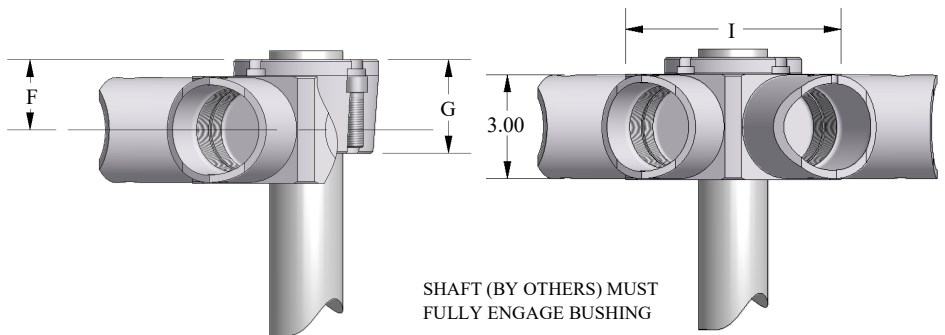

WITH FAN OPERATING AT  
12000 FT/MINUTE BLADE TIP SPEED

DIA	PERCENT BLADE LOADING						
	100%		75%		C	D	H
	A	B	B	C			
4'	5.0"	1.2"	0.9"	3.2"	2.0"	7.0"	
5'	4.6"	1.5"	1.1"	3.5"	2.0"	7.0"	
6'	4.2"	1.8"	1.4"	3.8"	2.0"	7.0"	
7'	3.8"	2.1"	1.6"	4.1"	2.0"	7.0"	
8'	3.4"	2.6"	2.0"	4.6"	2.0"	7.0"	

MAX BLADES	BUSHING TYPE	MAX # BORE	MAX * BORE	MAX o BORE	I	F	G	L
6	U	2.750"	2.938"	75	7"	2.0"	2.7"	4000
8	U	2.750"	2.938"	75	9"	2.0"	2.7"	4000