

NOTE:1  
 MAXIMUM FAN DIAMETER (BLADES HORIZONTAL - AS SHIPPED) EQUALS NOMINAL FAN DIAMETER. ADJUSTMENT OF ±1.5 INCHES POSSIBLE AT INSTALLATION

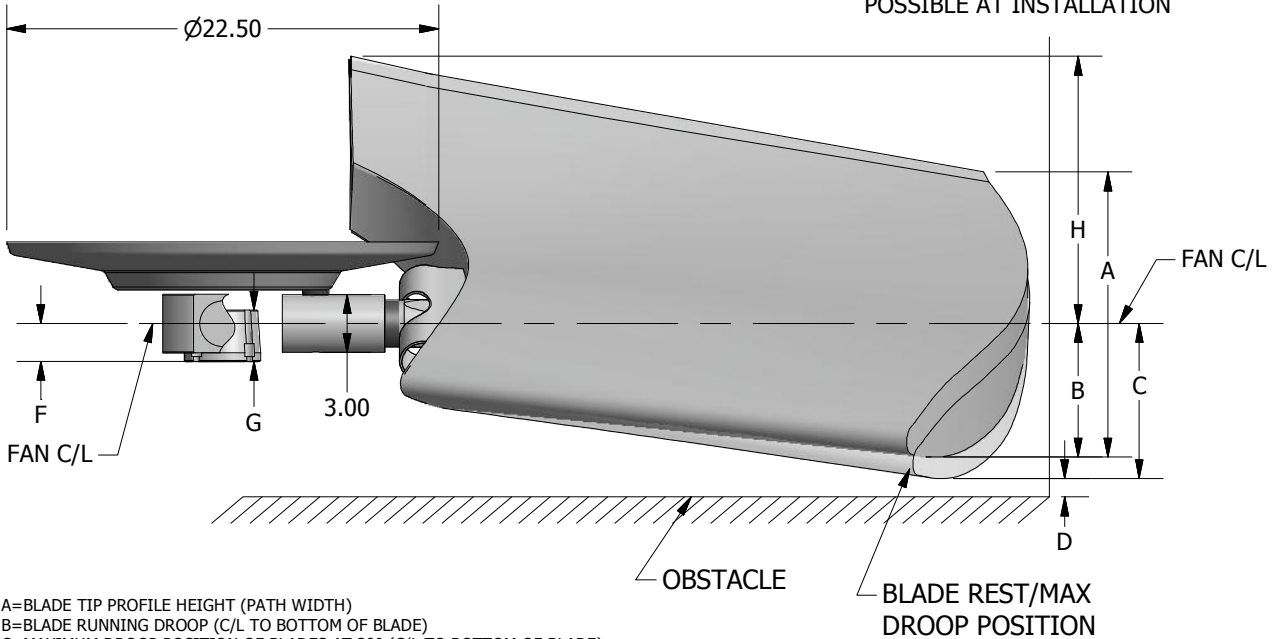

A=BLADE TIP PROFILE HEIGHT (PATH WIDTH)  
 B=BLADE RUNNING DROOP (C/L TO BOTTOM OF BLADE)  
 C=MAXIMUM DROOP POSITION OF BLADES AT 30° (C/L TO BOTTOM OF BLADE)  
 D=MINIMUM RECOMMENDED OBSTACLE CLEARANCE ON AIR INLET SIDE  
 H=MAXIMUM HEIGHT OF BLADE AT 30° (C/L TO AIR OUTLET SIDE)

F=FAN CENTERLINE TO BASE OF BUSHING (STANDARD HUB WITHOUT EXTENSION)  
 G=OVERALL BUSHING HEIGHT  
 L=MAX BUSHING TORQUE FT. LBS  
 #=WITH S.A.E. STANDARD KEYWAY IN BUSHING  
 \*=WITH SHALLOW KEYWAY IN BUSHING  
 °=MAX METRIC BORE WITH STANDARD KEYWAY

DIA	BLADE ANGLE		PERCENT BLADE LOADING		B	C	D	H
	10°	20°	30°	100%				
7.0'	9.0"	14.0"	19.3"	13.9"	13.4"	15.9"	6"	15.4"

BUSHING TYPE	NUMBER OF BLADES	MAX # BORE	MAX * BORE	MAX ° BORE	F	G	L
U	3,4	2.75"	2.938"	75	2.525"	2.7"	4000



# SERIES 24 - 7 FT DIAMETER FAN RIGHT HAND ROTATION