

NOTE 1: MAXIMUM FAN DIA. BLADES HORIZONTAL (AS SHIPPED) EQUALS NOMINAL FAN DIA. A ± 1.5 " ADJUSTMENT MAY BE MADE DURING INSTALLATION

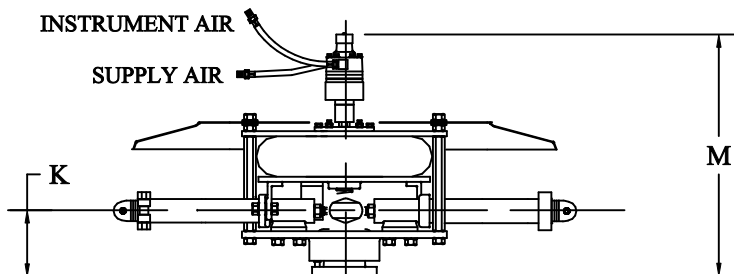
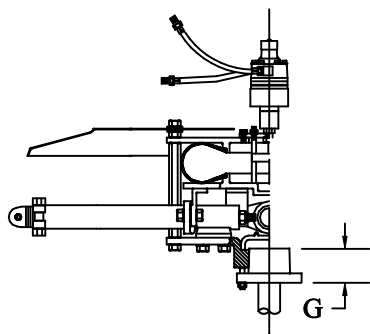
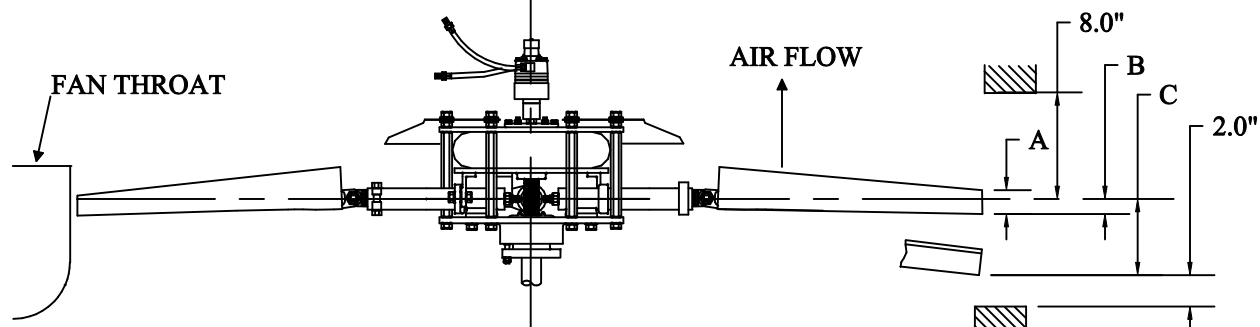

SHAFT SHOULD ENGAGE FULL BUSHING LENGTH. DO NOT EXTEND SHAFT MORE THAN 0.5" ABOVE BUSHING.

LETTER DIMENSIONS MAY VARY WITH BLADE ANGLE AND LOADING

WITH FAN OPERATING AT 12000 FT : MINUTE
BLADE TIP SPEED
PERCENT BLADE LOADING

DIA	PERCENT BLADE LOADING		
	100%	75%	
6'	4.6"	1.5"	3.5"
7'	4.2"	1.8"	3.8"
8'	3.8"	2.1"	4.1"
9'	3.4"	2.6"	4.6"
10'	3.0"	3.1"	5.1"
11'	2.6"	3.8"	5.8"
12'	2.2"	4.6"	6.6"

A = BLADE TIP THICKNESS
B = RUNNING POSITION OF BLADES
C = MAXIMUM DROOP POSITION OF BLADES
G = BUSHING OVERALL HEIGHT
K = CENTERLINE OF FAN TO BASE OF BUSHING

MAX. NO. BLADES	BUSHING TYPE	MAX. BORE STANDARD KEYWAY	MAX. BORE SHALLOW KEYWAY	DIM "G"	DIM "K"	DIM "M"
8	QDSF	2.250"	2.688"(60 mm)	2.1"	5.8"	21.1"
8	QDE	2.875"	3.50"(80mm)	2.7"	5.8"	21.1"

NOTES

SERIES 36 CSP AUTOMATIC FAN